

Management network & Web server

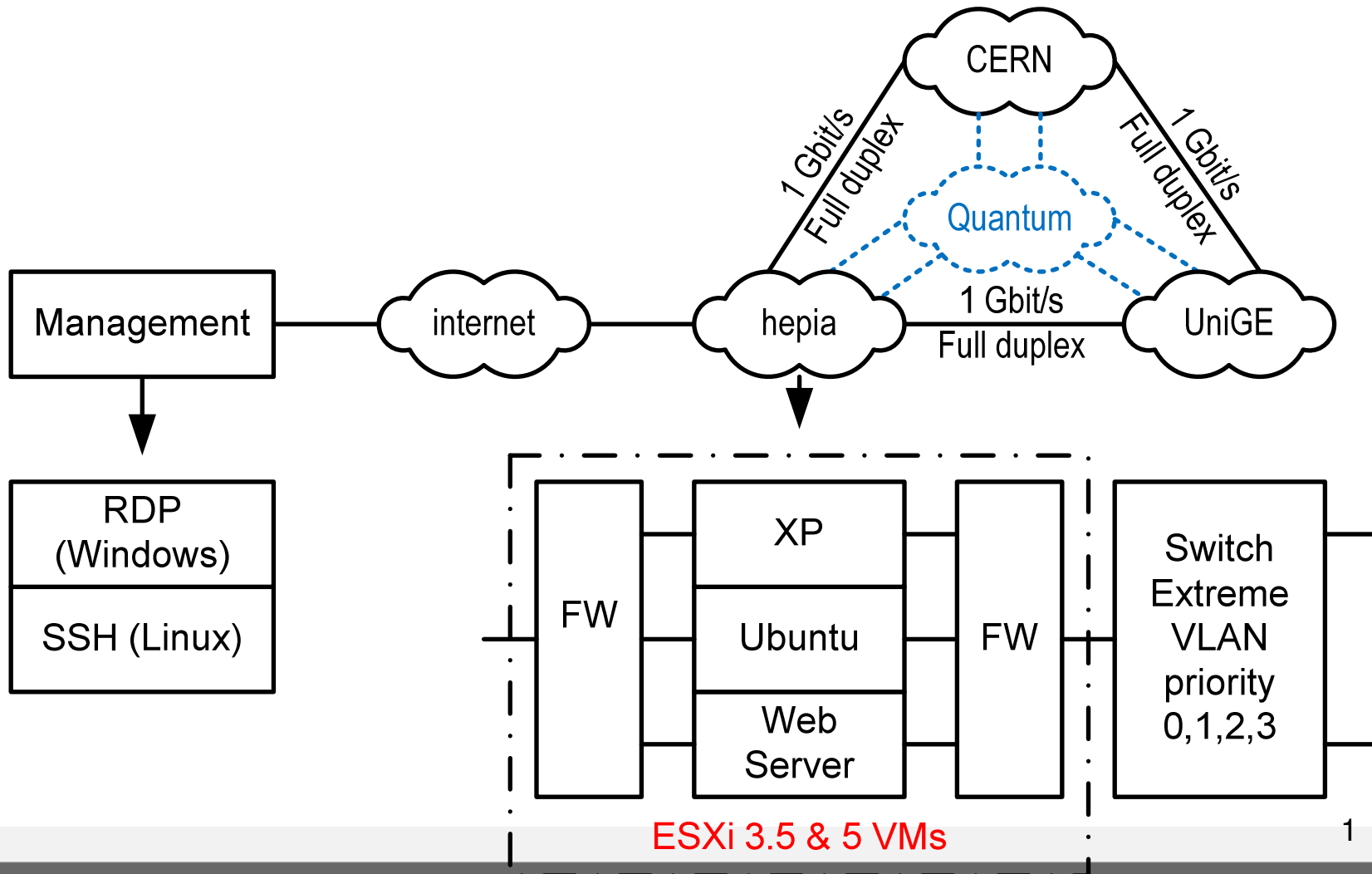

- Design network based on redundancy, Extreme switches & VLAN priorities
- Configuration of firewalls, management stations & web server
- Architecture virtualized with VMware ESXi 3.5
- New formation module proposed
- Definition of application context (video for inelastic traffic, ...) & Quality of Service

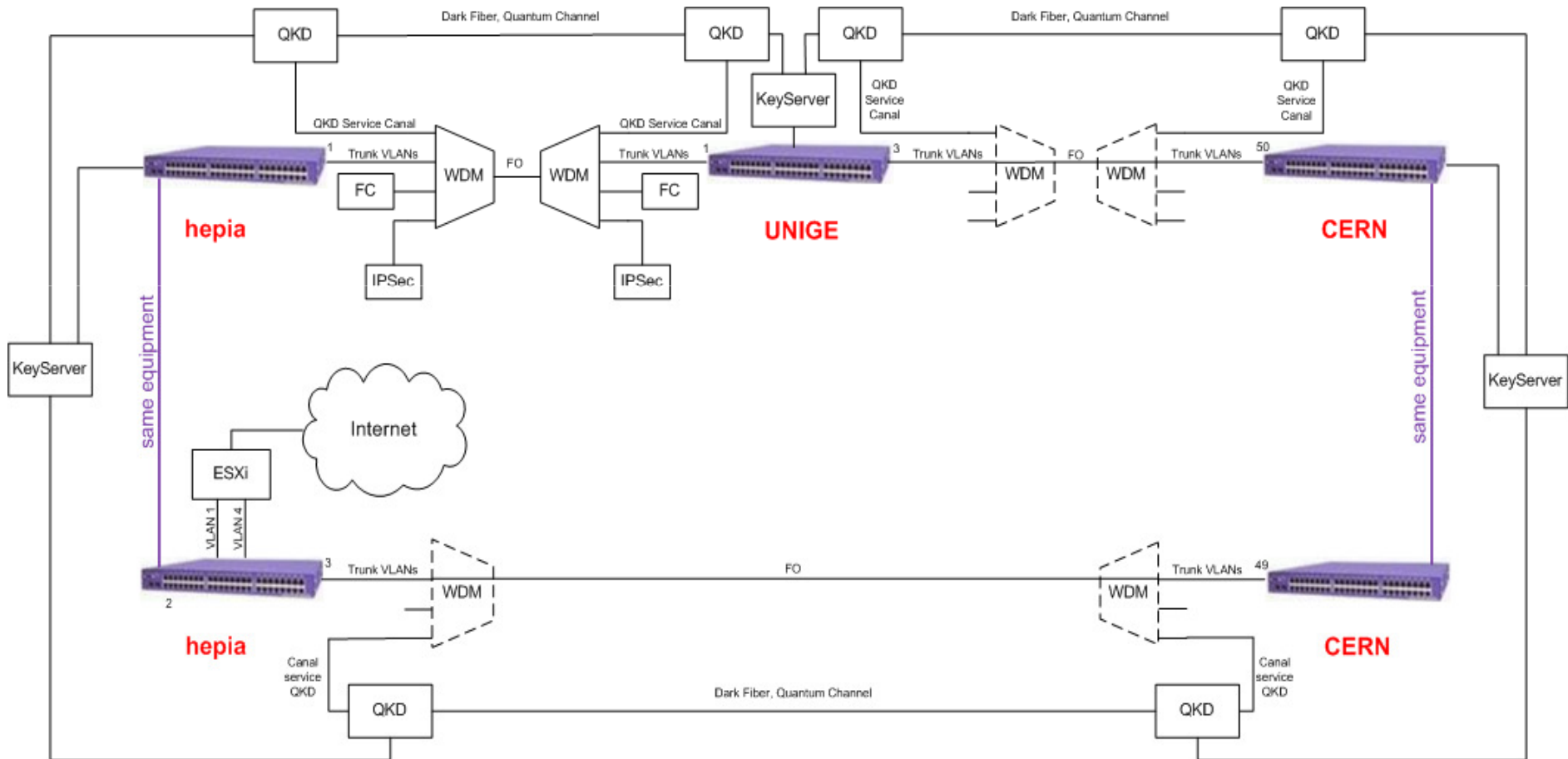

- The QoS Test Software Suite is a 'passive' tools for QoS Measurements
- To allow the probes and the QoS Manager to measure higher throughput, the proposed measurement methodology is based on time 'sampling' and traffic 'filtering'
- The sampling and filtering technics for traffic flow is based on the IETF draft 'draft-ietf-psamp-sample-tech-04.txt' by Zseby, Molina, Raspall and Duffield

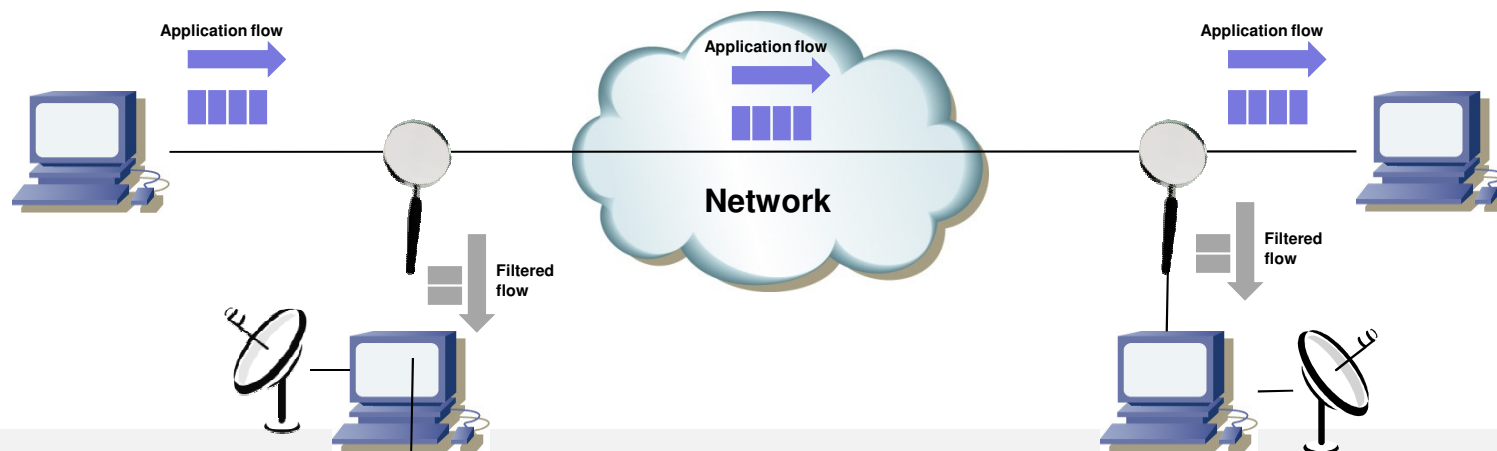

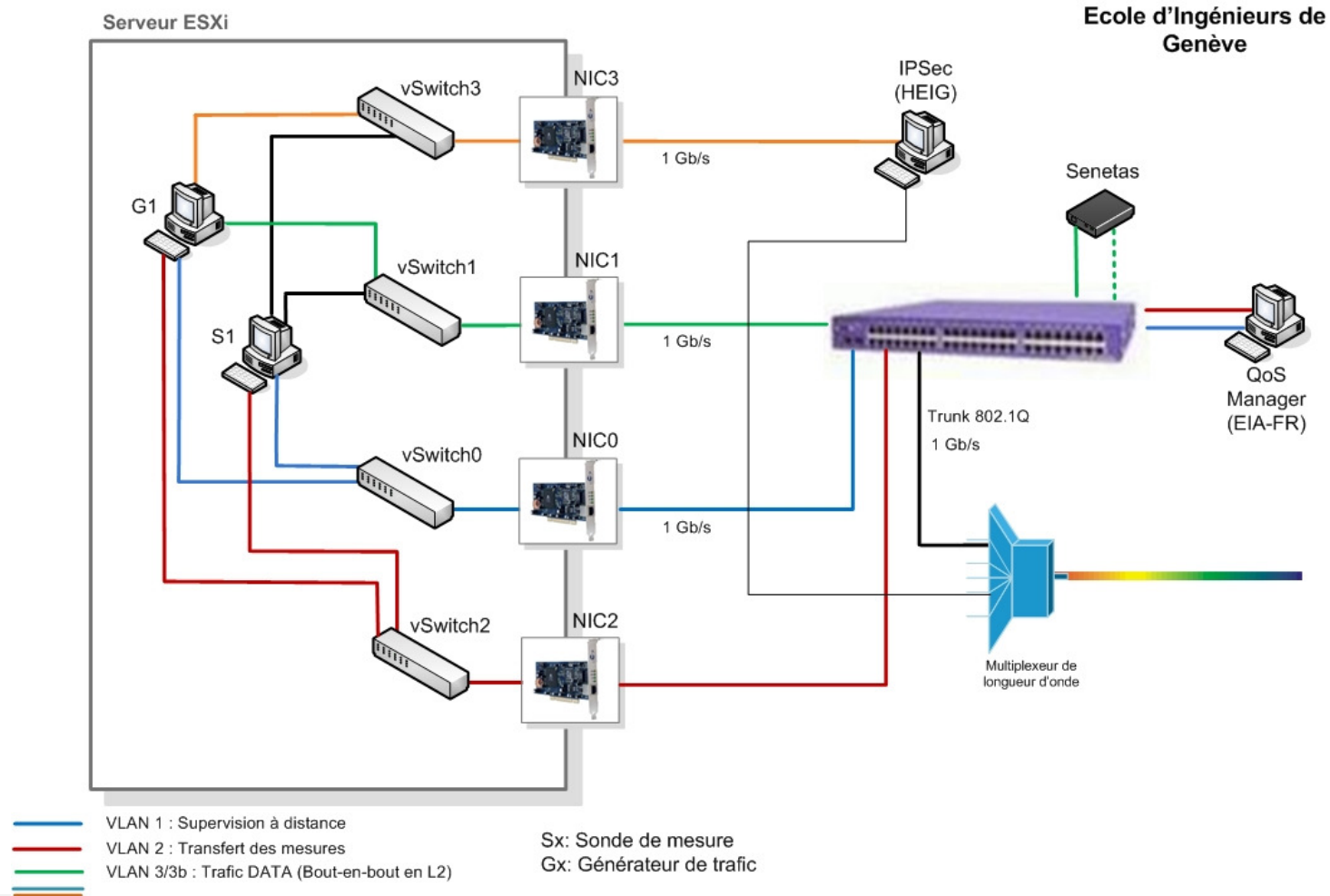

Measure: UDP flow filtered by IP source address on a 20 Mbps TCP/UDP flow

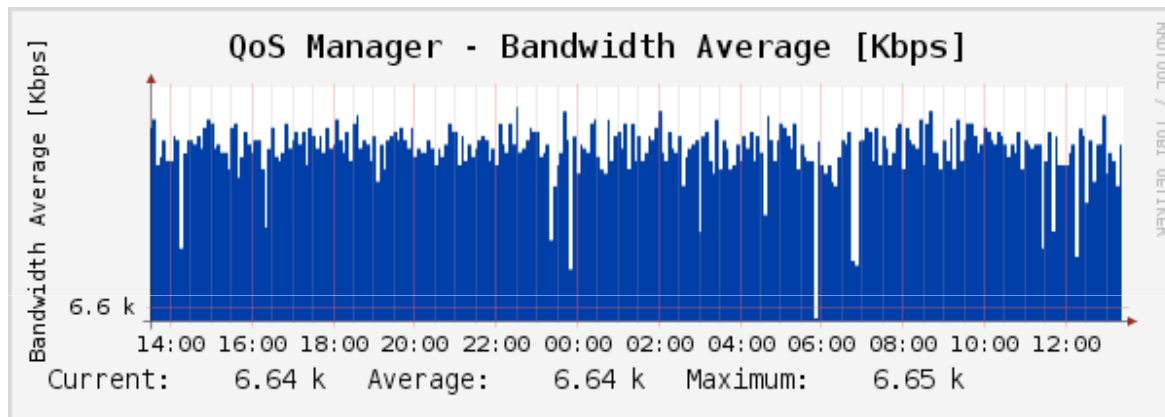

6.6 Mb/s Average

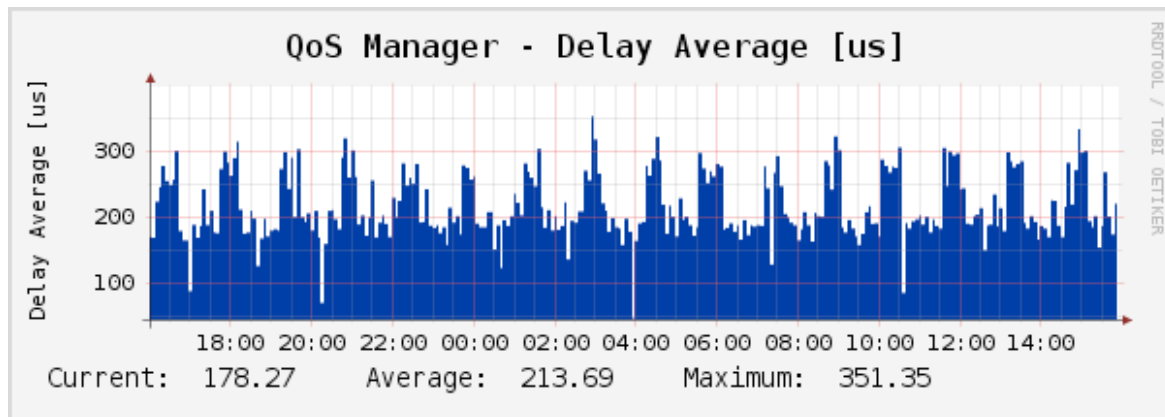

214 ms Average

- Availability in 'real-time' of QoS Result through MIB's accessible via SNMP

- QoS Test Software Suite characteristics:
 - Based on Open Source standard libraries (libpcap)
 - Probe synchronisation through NTP
 - UDP throughput up to 80 Mb/s on real machine (running Linux)
 - UDP throughput up to 15 Mb/s on virtual machine (on top of VMWare ESXi)

- Secure integration of the Quantum Key Distribution protocol within an IPsec stack
- Allows a cryptographically robust fail-over in case of defective or unavailable quantum link
- Prototype based on a modified Racoon's IKE implementation and state-of-the-art cryptographic algorithms
- Throughput of up to 400 Mbps on commodity PCs running under Linux

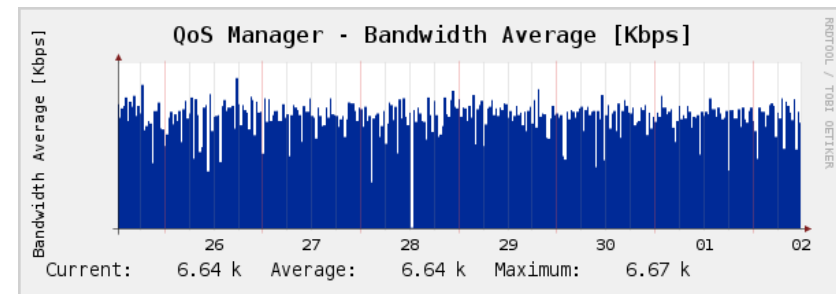
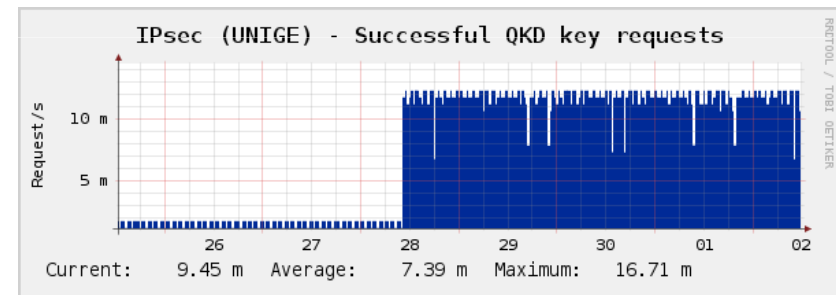
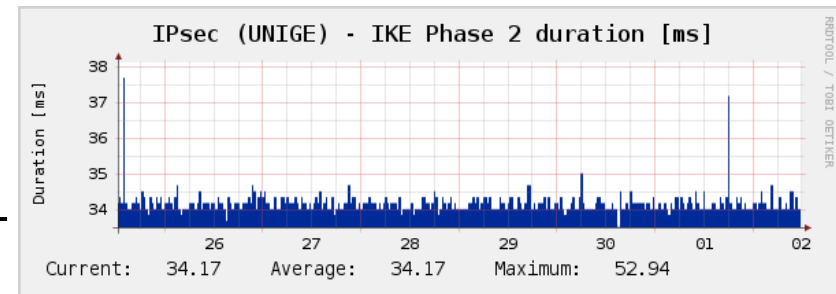

Inter-site Data Links

Local Data

Management Network

VPN Network

